

4

3

2

1

THIS DRAWING IS UNPUBLISHED.
DIFFUSION RESEINTE AMP

RELEASED FOR PUBLICATION

.19

LOC DIST
FH 00

REVISIONS

© COPYRIGHT 1997

BY AMP INCORPORATED. ALL RIGHTS RESERVED.
TOUS DROITS RESERVES

P	LTR REV	DESCRIPTION MODIFICATIONS	DATE	DWN DESS.	APVD APP.
A		FF045	19/01/94	-	-
B		FJ0003	8-Jan-98	EN	HV
C		EQ00-0200-08	25-Apr-08	EN	LR

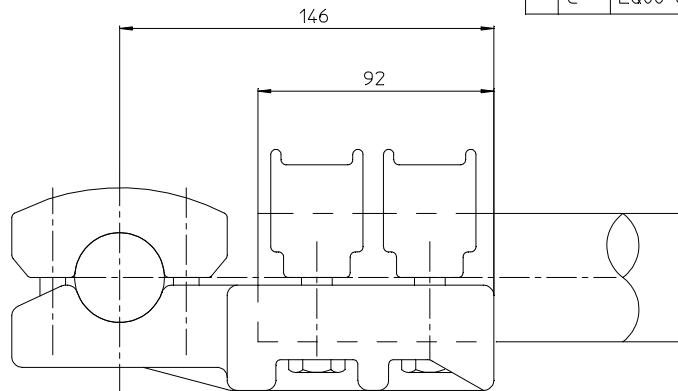

Tube ou Borne ø46 à 50.99
 Tube or terminal 46DIA to 50.99
 Tubo o Borna ø46 a 50.99

Cable ou tube ø31 à 35.99
 Cable or tube 31DIA to 35.99
 Cable o tubo ø31 a 35.99

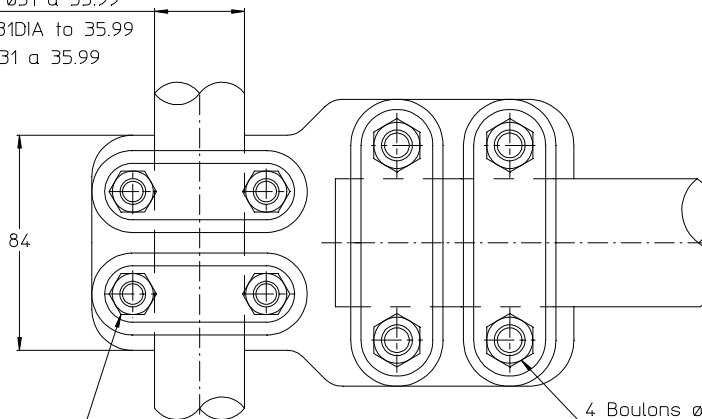

4 Boulons ø12 acier inox A2
 4 Bolts 12DIA stainless steel A2
 4 Tornillos ø12 acero inoxidable A2 } 60 Nm

37 Nm { 4 Boulons ø10 acier inox A2
 4 Bolts 10DIA stainless steel A2
 4 Tornillos ø10 acero inoxidable A2

<small>THIS DRAWING IS A CONTROLLED DOCUMENT FOR AMP INCORPORATED. IT IS SUBJECT TO CHANGE AND THE CONTROLLING ENGINEERING ORGANIZATION SHOULD BE CONTACTED FOR THE LATEST REVISION. CE PLAN EST UN DOCUMENT CONTRÔLÉ PAR AMP INCORPORATED. IL EST SUSCEPTIBLE D'ÊTRE REVISÉ, CONTACTER LE SERVICE TECHNIQUE D'AMP SIMEL POUR OBTENIR LA DERNIÈRE REVISION.</small>		DWN /DESSINE 19/01/94 Vogel P. CHK /VERIFIE 25-Apr-08 GODARD		SIMEL PRODUCTS	
DIMENSIONS: mm		TOLERANCES UNLESS OTHERWISE SPECIFIED PER TOLERANCES NON SPECIFIEES SELON : -		APVD /APPROUVE - ROYER NAME TITRE T 82 35 50	
		PRODUCT SPEC SPEC. PRODUIT 02BFC0031		SIZE FORMAT A3	
MATERIAL MATIERE -		FINISH FINITION -		CAGE CODE 00779 DRAWING NO No PLAN ©-716196	
		WEIGHT MASSE APPROX. 1.65 KG		UNQUEMENT FOUR REFERENCE	
		CUSTOMER DWG / PLAN CLIENT		SCALE ECHELLE 1/2	
				SHEET FEUILLE 1 OF 1	
				REV C	

ITEM: